

K-1000

M&T

Instructions

Repair Parts List



Henkel, Inc.
P.O. Box 1322
Hammond, LA
70404

(985) 345-2171

www.keenovens.com



Henkel, Inc.

P.O. Box 1322 * Hammond, Louisiana * 70404 * (985) 345-2171
www.keenovens.com

**Model K-1000 M&T Holding Ovens
Installation Instructions & Repair Parts List**

One Year Limited Warranty

.....
Henkel, Inc. warrants its products against defects in material and workmanship. Henkel, Inc. will either repair or replace without charge any properly installed product which fails under normal operating conditions within one year from date of installation, provided it is returned to our factory, transportation prepaid, and our inspection determined it to be defective under the terms of this warranty. The warranty covers only equipment manufactured by Henkel, Inc., and does not extend to transportation, installation, or replacement charges at the buyers' facility; nor does it apply to any other equipment of another manufacturer used in conjunctions with Henkel, Inc. equipment. No other warranty, expressed or implies exists beyond that included in this statement.
.....

Keen Ovens

Model K-1000 M&T

SPECIFICATIONS

Capacity	18 12" Spools
Volts	120 V / 240 V
Watts	250 W / 1000 W
Thermostat	Dial Adjustable; Range 50-250°F
Temperature	50°F-250°F
Insulation	2"
Interior Dimensions	27.5" X 20.5" X 40"
Net Weight	300 lbs.
Shipping Weight	335 lbs.
Shipping Dimensions	39.5" X 32.5" X 55"

Recommended Spare Parts

**When it is critical to have continuous operation of this unit;
we suggest having the following spare parts on hand:**

**Heating Element Assembly
Power Cord
Thermostat Assembly & Thermometer Kit**

General Information

The K-1000 M&T is the only oven on the market designed for Mig and Tig storage. Spools are safely cradled to prevent them from rolling out. Custom shelf arrangements are available. A filler material rack located on the door has seven compartments for storage of 36" long filler material. Construction is of steel that has been treated and then painted with a chemical-resistant blue finish. All Keen ovens are Mercury free.

Safety Precautions

Read all instructions completely before attempting to operate this unit.

***** SAVE THESE SAFETY INSTRUCTIONS *****

To reduce the risk of electrical shock, fire, or personal injury follow the guidelines below:

- Before connecting unit to a power source, be sure the voltage supplied is the same as that specified on the name plate of the unit.
- Check outlet to ensure proper grounding of the electrical cable. Have a licensed electrician check the A/C power outlet if you are not sure.
- Use this unit for its intended purpose as described by literature.
- Make sure power cord is located so that it will not be stepped on, tripped over, or otherwise subjected to stress of heat, oil, or sharp edges. Do not close doors on the cord.
- To reduce the risk of damage to the electric plug and cord, disconnect by plug rather than by the cord.
- Do not use this unit if cord or plug is in poor condition. If it has been exposed to weather or immersed in water, have a qualified serviceman inspect and replace parts as necessary.
- **WARNING! NEVER HANDLE PLUG, CORD, OR UNIT WITH WET HANDS OR WHILE STANDING IN WATER.**
- Use special care when moving heavily loaded units.

- Do not store combustible material on or around the unit.
- Do not operate this unit empty.
- When using the unit at a distance where an extension cord becomes necessary, a 3-conductor grounding cord of adequate size must be used for safety, and to prevent loss of power and overheating. Use only a UL listed extension cord suitable for outdoor use. Make certain wire size is large enough for A/C amperage rating of unit.

Operation

Locate oven in an area free of combustible material and close to an appropriate electrical power source. Load oven with spools and filler material to be stored. To turn on unit, simply plug the power cord into an appropriate single phase A/C source and adjust the thermostat to desired setting. The oven is supplied with a 6' UL listed 16/3 SJ power cord. The unit will operate on 120 V with 250 watts of heat, or 240 V with 1000 watts of heat. Electrical plugs are not supplied with the unit due to the many different receptical configurations in the field. When attaching plug to power cord, be sure plug is an approved component and is rated for the proper voltage and amperage.

Temperature Setting

The thermostat is adjustable from 50°F (10° C) to 250°F (121.5°C). Turn the thermostat knob to desired temperature by aligning with red line on chrome bezel.

***** CAUTION: DO NOT USE ON D/C POWER SUPPLY! *****

Venting

Keen oven model K-1000 M&T is vented through two screened vent plugs at the rear of the oven.

Functional Description

The K-1000M&T oven is designed for the storage of Mig & Tig welding materials at an optimum low temperature. Storage shelves are fabricated from perforated steel to allow complete air circulation throughout the oven. The shelving system consists of three shelves that securely cradle wire spools and prevent them from rolling out. The filler material rack is located on the inside of the door. This rack is divided into seven compartments for the segregated storage of 36" long filler material. Custom shelving is also available for the storage of different size spools or coils.

Scheduled Maintenance

The manufacturer recommends that the unit be unloaded and cleaned of debris and dust every six months. It is also recommended that a temperature probe be placed inside the unit and the thermostat calibration checked at this time.

Troubleshooting

The Keen oven models K-1000 M&T requires a minimal amount of electrical knowledge to repair if necessary.

IF OVEN FAILS TO OPERATE – NO HEAT

1. Check power source.
2. Check power cord continuity. Replace cord assembly if faulty.
3. If pilot light glows, voltage is being supplied by elements. Check elements. Check element continuity. If defective, replace.
4. If thermostat cannot be heard clicking on and off when dial is rotated, and if pilot light fails to operate, replace thermostat.

IF OVEN OVERHEATS

If oven fails to cycle on and off and reaches temperatures above 250°F thermostat is faulty and needs replacing.

Corrective Maintenance

CHANGING THE HEATING ELEMENT

1. Disconnect oven from power source.
2. Remove back cover, insulation and element cover.
3. Remove cover plate from handy box and remove wire connectors from element leads.
4. Remove hex nuts from element mounting bolts and remove insulators, element and element brackets.
5. Install new element, brackets and insulators. (New brackets, insulators and leads are supplied with elements.)
6. Reconnect element leads as per wiring diagram.
7. Check that element leads and terminals are not grounded to oven body.
8. Replace insulation, element cover, back cover, and handy box cover plate.

THERMOSTAT CALIBRATION & ADJUSTMENT

1. Turn on unit. Set control dial at desired temperature.
2. Allow control to cycle at least three times and observe temperature at the middle of the fourth cycle.
3. If calibration is required, carefully remove dial knob. Do not turn shaft.
4. Turn calibration screw in center of dial shaft clockwise to lower temperature and counter-clockwise to increase temperature.
5. Allow unit to cycle three times and observe temperature at middle of fourth cycle. Readjust calibration screw if necessary.
6. Replace dial knob.

CHANGING THE THERMOSTAT

1. Disconnect from the power source.
2. Remove cover plate from control box and disconnect wire connectors from thermostat leads.
3. Remove thermostat knob and chrome bezel. Remove thermostat from control box and pull sensing bulb from oven wall
4. Place thermostat leads on new thermostat and insert sensing bulb through oven wall being sure there is adequate length to reach holder.
5. Loosely attach thermostat and chrome bezel to control box. Place knob on thermostat and adjust bezel so that knob turns freely. When knob turns freely, remove knob, tighten bezel, and replace and tighten knob.
6. Rewire element leads as per wiring diagram and replace control box cover.

K-1000 M&T Wiring Diagram 120V / 250W 240V / 1000W

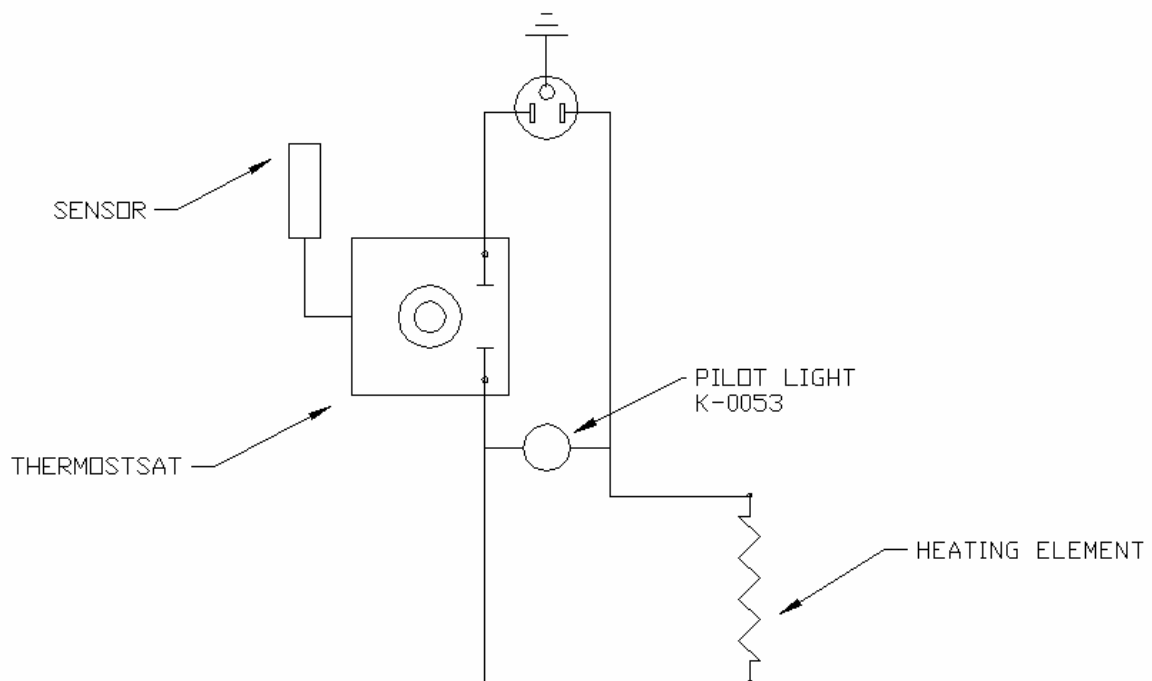

Model K-1000 M&T Repair Parts List

ITEM #	QUANTITY	DESCRIPTION	PART NUMBER
1	1	Neon Pilot	301085
2	1	Power Cord	301018
3	1	Thermostat Assembly	301037
4	3	Heating Elements	301026
5	1	Handy Box	301038
6	2	Draw Pull Catches	430106
7	1	Strain Relief	301041
8	1	Door Pull	430102
9	1	Door	
10	3	Shelf Assembly	
11	1	Element Cover	
12	1	Door Rack	
13	1	Back Cover	
14	1	Control Box	
15	1	Name Plate	450103

K-1000 M&T ACCESSORIES LIST

** Please state model number and serial number and specify voltage and wattage when ordering repair parts, spare parts, or accessory parts. All necessary attaching hardware is supplied with each part ordered

(Item numbers refer to pictorial drawings below for repair parts.)

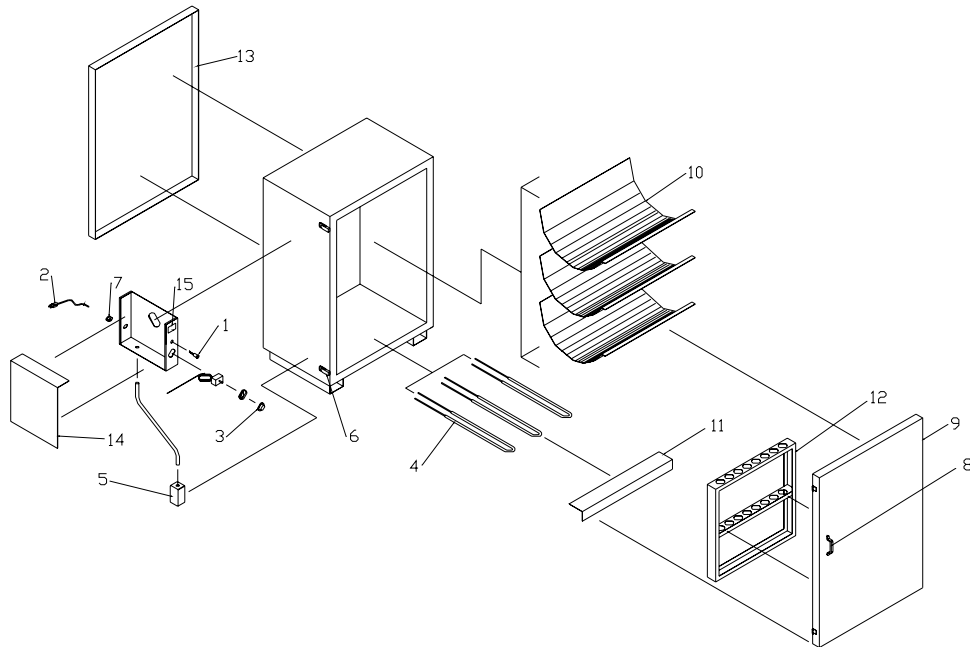



HENKEL, INC.
 Manufacturer of KEEN Ovens
Quality Since 1923.

Phone (985) 345-2171
 Fax (985) 345-5653
 PO Box 1322
 Hammond, Louisiana
 70401

Flux and Electrode Stabilizing Ovens

Type (AWS)	Air Conditioned Storage Before Opening	Dry Rod Oven Holding After Opening	After Exposure to Moisture a Sufficient Time to affect Weld Quality	
			Recondition Step 1	Rebake Step 2
Standard EXX10 EXX11 EXX12 EXX13 EXX20 EXX30	80°F ± 20° 60% ± 10% RH	140°F ± 30°	180°F ± 25° two hours	240°F ± 25° one hour
			Three hour total	
Iron Powder EXX14 EXX24 EXX27	90°F ± 20° 50% RH max	140°F ± 30°	180°F ± 25° two hours	325°F ± 25° one hour
			Three hour total	
Iron Powder-Low Hydrogen EXX18 EXX28	90°F ± 20° 50% RH max	400°F ± 50°	180°F ± 25° two hours	700°F ± 100° one-half hour
			Two & one-half hour total	
Low Hydrogen EXX15 EXX16	90°F ± 20° 50% RH max	400°F ± 50°	180°F ± 25° two hours	600°F ± 100° one-half hour
			Two & one-half hour total	
Low-Hydrogen High Tensile EXXX15 EXXX16	90°F ± 20° 50% RH max	400°F ± 50°	180°F ± 25° two hours	700°F ± 100° one-half hour
			Two & one-half hour total	
Stainless Inconel Monel Nickel Brasses Bronzes Hard Surfacing Special Alloys	90°F ± 20° 50% RH max	225°F ± 50°	180°F ± 25° one hour	350°F ± 50° one hour
			Two hour total	
Granulated or Agglomerated Flux	90°F ± 20° 50% RH max	240° F ± 50°	Not required	700°F ± 100° two hours

IMPORTANT:
 This table is offered as a guide to proper storage and oven holding temperatures for the most common electrodes in use today. In addition, recondition/rebake procedures for electrode coatings that have been exposed to moisture for a sufficient period of time to affect the weld quality are included. Good judgment and the manufacturer's recommendations should be your guide.

Note: In the HTS Stainless electrode groups, and 15 & 16 type coatings, there can be a greater difference in the maximum temperature requirements for rebaking than those shown. This can be handled by special request to the particular manufacturer involved.

.....
 CONTACT YOUR ELECTRODE MANUFACTURER FOR SPECIFIC INFORMATION INVOLVING CRITICAL OPERATIONS.

Electrode coating should not be exposed to the rebaking temperature without first having been reconditioned at a lower temperature. Failure to observe this rule will result in breakdown of electrode coatings.