

**KE-300**

**Installation Instructions**  
**Repair Parts List**



Henkel, Inc.  
P.O. Box 1322  
Hammond, LA  
70404

(985) 345-2171

[www.keenovens.com](http://www.keenovens.com)

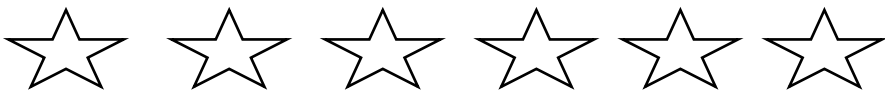

**Henkel, Inc.**

P.O. Box 1322 \* Hammond, Louisiana \* 70404 \* (985) 345-2171  
www.keenovens.com

**Model KF-300 Flux Oven  
Installation Instructions & Repair Parts List**

One Year Limited Warranty

.....  
Henkel, Inc. warrants its products against defects in material and workmanship. Henkel, Inc. will either repair or replace without charge any properly installed product which fails under normal operating conditions within one year from date of installation, provided it is returned to our factory, transportation prepaid, and our inspection determined it to be defective under the terms of this warranty. The warranty covers only equipment manufactured by Henkel, Inc., and does not extend to transportation, installation, or replacement charges at the buyers' facility; nor does it apply to any other equipment of another manufacturer used in conjunctions with Henkel, Inc. equipment. No other warranty, expressed or implies exists beyond that included in this statement.  
.....

**Keen Ovens**  
Models KF-300  
Specifications

Capacity	300lbs. Flux		
Volts	120V	240V	480V
Watts	1000W	1000W	1000W
Thermostat	Dial Adjustable		
Temperature	150°F - 550°F		
Insulation	2"		
Hopper Dimensions	20" X 19" X 22"		
Net Weight	145lbs.		
Shipping Weight	171lbs.		
Shipping Dimensions	34" X 32" X 51"		

## Recommended Spare Parts

**When it is critical to have continuous operation of this unit;  
we suggest having the following spare parts on hand:**

### Heating Element Assemblies

### Thermostat

## General Information

The KF-300 is a portable, hopper-style, top loading flux oven. The bottom unloading design and slide valve allows for easy dispensing of flux. It is moveable on heavy duty casters. The unit is made of steel, treated, and then painted with a chemical-resistant blue paint. All Keen ovens are Mercury free.

## Safety Precautions

Read all instructions completely before attempting to operate this unit.

**\*\*\* SAVE THESE SAFETY INSTRUCTIONS \*\*\***

To reduce the risk of electrical shock, fire, or personal injury follow the guidelines below:

- Before connecting unit to a power source, be sure the voltage supplied is the same as that specified on the name plate of the unit.
- Check outlet to ensure proper grounding of the electrical cable. Have a licensed electrician check the A/C power outlet if you are not sure.
- Use this unit for its intended purpose as described by literature.
- Make sure power cord is located so that it will not be stepped on, tripped over, or otherwise subjected to stress of heat, oil, or sharp edges. Do not close doors on the cord.
- To reduce the risk of damage to the electric plug and cord, disconnect by plug rather than by the cord.
- Do not use this unit if cord or plug is in poor condition. If it has been exposed to weather or immersed in water, have a qualified serviceman inspect and replace parts as necessary.
- **WARNING! NEVER HANDLE PLUG, CORD, OR UNIT WITH WET HANDS OR WHILE STANDING IN WATER.**
- Use special care when moving heavily loaded units.

- Do not store combustible material on or around the unit.
- Do not operate this unit empty.
- When using the unit at a distance where an extension cord becomes necessary, a 3-conductor grounding cord of adequate size must be used for safety, and to prevent loss of power and overheating. Use only a UL listed extension cord suitable for outdoor use. Make certain wire size is large enough for A/C amperage rating of unit.

## Operation

Load oven with 300lbs. of flux. To turn unit on, simply plug the power cord into the appropriate single phase A/C source and adjust thermostat to desired setting. All flux ovens are supplied with 6' UL listed type SJ cord. However, due to the many different receptical configurations in the field, a plug is not supplied.

When attaching the plug to the power cord, be sure the plug is an approved component and is rated for the proper voltage and amperage. All units meet electrical code requirements when used with a grounding plug and a grounded receptical. To dispense flux from oven simply place a container on bottom shelf of oven and pull slide valve open.

**\*\*\* CAUTION: DO NOT USE ON D/C POWER SUPPLY! \*\*\***

## Venting

The KF-300 is designed to vent around the perimeter of the lid while still maintaining temperature.

## Temperature Setting

The thermostat is adjustable from 150°F (37.8 C) to 550°F (287.8 C). Turn thermostat knob to desired temperature by aligning with red line on chrome bezel.

Pilot light indicates when power is supplied to the heating element. The thermostat is accurate to  $\pm 25^{\circ}\text{F}$  (14 C) at the sensor.

## Guide to Storage

See the enclosed guide to storage. This guide may be used in the absence of storage information from the flux manufacturer. In critical situations, contact your flux manufacturer.

## Functional Description

The model KF-300 is designed to store 300lbs. of welding flux at moderate optimum temperature. Due to the location of the elements in the storage hopper and the construction of the heating elements, this unit will stabilize flux in a minimal amount of time.

The oven is top loading and welding flux is easily dispensed through a slide valve located at the bottom of the oven. The oven is mounted on heavy-duty casters allowing the operator to move 300lbs. of stabilized flux to the welding area.

## Scheduled Maintenance

The manufacturer recommends that after each use the operator cleans all flux residue from elements and element brackets. Flux buildup of elements may cause hop spots and shorten element life.

## Troubleshooting

The Keen oven model KF-300 requires a minimal amount of electrical knowledge to repair if necessary.

### IF OVEN FAILS TO OPERATE – NO HEAT

1. Check power source.
2. Check power cord continuity. Replace cord assembly if faulty.
3. If thermostat cannot be heard clicking on and off when dial is rotated, and if pilot light fails to operate, check thermostat for continuity. If faulty, replace.
4. If thermostat is good, check continuity of element. If continuity is not present, replace element.

### IF OVEN HEATS BUT FAILS TO REACH TEMPERATURE

One or more elements may be faulty. Check continuity and replace faulty elements.

### IF OVEN OVERHEATS

If oven fails to cycle on and off and reaches temperatures over 550°F, thermostat is faulty and needs replacing.

### IF OVEN OPERATES BUT IS OFF FROM SETTING

See “Thermostat Calibration” instructions. NOTE: When replacing any components, refer to “Corrective Maintenance” section of this manual for instructions.

## Corrective Maintenance

### CHANGING HEATING ELEMENTS

1. Disconnect power source.
2. Empty oven of flux.
3. Remove control box cover plate and remove wire connectors from element leads.
4. Remove element cover and element leads on elements to be changed. (Be sure to use backup wrench on element terminals.)
5. From interior of oven, unbolt element bracket and remove element and insulators.
6. Pass new element from side wall of oven and rebolt element bracket and insulators in place. (New element brackets and insulators are shipped with replacement elements.)
7. Replace element leads using a backup wrench to tighten terminals.
8. Replace element cover and reconnect element leads in control box. Replace control box cover.

## Model KF-300 Wiring Diagram

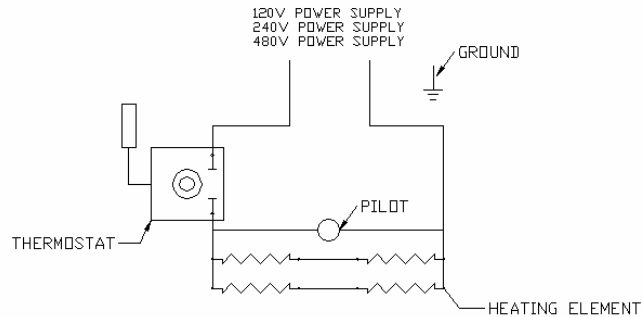

## CHANGING THE THERMOSTAT

1. Disconnect from the power source.
2. Remove cover plate from control box.
3. Remove wire connectors (2) from thermostat leads.
4. Loosen set screw on thermostat knob and remove knob.
5. Unscrew and remove chrome bezel.
6. Thermostat may now be removed from control box and thermostat sensing tube pulled from holder.
7. To replace new thermostat, attach leads from old thermostat to new. Uncoil an adequate length of the sensing tube to reach center of oven.
8. Place thermostat in control box and loosely mount chrome bezel in place with red indicating line in upward position.
9. Place knob on thermostat and adjust bezel so knob turns freely. When knob turns freely, remove and tighten bezel, replace knob and tighten set screw.
10. Reconnect electrical leads as per wiring diagram. Replace cover plate.

## THERMOSTAT CALIBRATION & ADJUSTMENT

1. Turn on unit. Set control dial at desired temperature.
2. Allow control to cycle at least three times and observe temperature at middle of fourth cycle.
3. If calibration is required, carefully remove dial knob. Do not turn shaft.
4. Turn calibration set screw in center of dial shaft counter-clockwise to increase temperature and clockwise to lower temperature. Allow unit to cycle three times and observe temperature at middle of fourth cycle.
5. Readjust calibration screw if necessary. Replace dial knob.

## Model KF-300 Repair Parts List

ITEM#	QUANTITY	DESCRIPTION	PART NUMBER	
1	1	Thermometer	301127	
2	2	Handles	430102	
3	1	Thermostat Assembly	301038	
4	1	Power Cord	120 V	301155
			240 V	301018
			240V 3PH	301095
			480V	301094
			480V 3PH	301095
5	1	Neon Pilot	120 V/240 V	301085
			480 V	301101
6	4	Element Assembly	120 V/1000 W	301023
			240 V/1000 W	301026
			480V 1000W	301029
7	1	Lid		
8	1	Element Cover		
9	1	Control Box		
10	1	Door Prop		
11	1	Strain Relief	301043	
12	1	Name Plate	450103	
13	1	Bucket Stop		
14	1	Valve Slide		

### KF-300 ACCESSORIES LIST

\*\*Please state the model number and the serial number and specify voltage and wattage when ordering repair parts, spare parts, or accessory parts. All necessary attaching hardware is supplied with each part ordered.  
*(Item numbers refer to pictorial drawings below for repair parts.)*

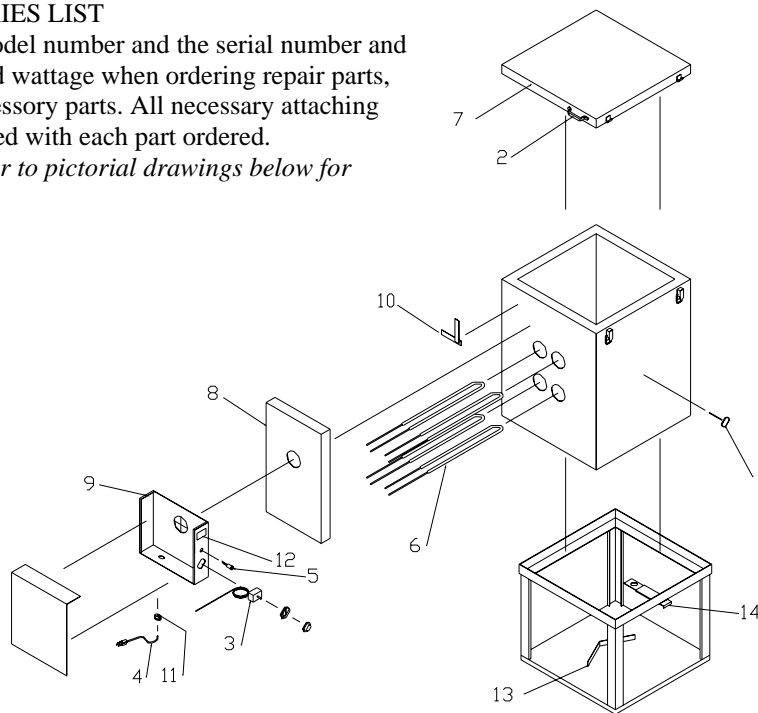



# HENKEL, INC.

Manufacturer of KEEN Ovens  
Quality Since 1923.

Phone (985) 345-2171  
Fax (985) 345-5653  
PO Box 1322  
Hammond, Louisiana  
70401

## Flux and Electrode Stabilizing Guide

Type (AWS)	Air Conditioned Storage Before Opening	Dry Rod Oven Holding After Opening	After Exposure to Moisture a Sufficient Time to affect Weld Quality	
			Recondition Step 1	Rebake Step 2
<b>Standard</b> EXX10 EXX11 EXX12 EXX13 EXX20 EXX30	80°F ± 20° 60% ± 10% RH	140°F ± 30°	180°F ± 25° two hours	240°F ± 25° one hour
			Three hour total	
<b>Iron Powder</b> EXX14 EXX24 EXX27	90°F ± 20° 50% RH max	140°F ± 30°	180°F ± 25° two hours	325°F ± 25° one hour
			Three hour total	
<b>Iron Powder-Low Hydrogen</b> EXX18 EXX28	90°F ± 20° 50% RH max	400°F ± 50°	180°F ± 25° two hours	700°F ± 100° one-half hour
			Two & one-half hour total	
<b>Low Hydrogen</b> EXX15 EXX16	90°F ± 20° 50% RH max	400°F ± 50°	180°F ± 25° two hours	600°F ± 100° one-half hour
			Two & one-half hour total	
<b>Low-Hydrogen High Tensile</b> EXXX15 EXXX16	90°F ± 20° 50% RH max	400°F ± 50°	180°F ± 25° two hours	700°F ± 100° one-half hour
			Two & one-half hour total	
<b>Stainless</b> Inconel Monel Nickel Brasses Bronzes Hard Surfacing Special Alloys	90°F ± 20° 50% RH max	225°F ± 50°	180°F ± 25° one hour	350°F ± 50° one hour
			Two hour total	
<b>Granulated or Agglomerated Flux</b>	90°F ± 20° 50% RH max	240° F ± 50°	Not required	700°F ± 100° ∅ two hours

**IMPORTANT:**  
This table is offered as a guide to proper storage and oven holding temperatures for the most common electrodes in use today. In addition, recondition/rebake procedures for electrode coatings that have been exposed to moisture for a sufficient period of time to affect the weld quality are included. Good judgment and the manufacturer's recommendations should be your guide.

*Note: In the HTS Stainless electrode groups, and 15 & 16 type coatings, there can be a greater difference in the maximum temperature requirements for rebaking than those shown. This can be handled by special request to the particular manufacturer involved.*

CONTACT YOUR ELECTRODE MANUFACTURER FOR SPECIFIC INFORMATION INVOLVING CRITICAL OPERATIONS.

Electrode coating should not be exposed to the rebaking temperature without first having been reconditioned at a lower temperature. Failure to observe this rule will result in breakdown of electrode coatings.

After rebake, lower temperature to *holding level* until reissue.